

MVBA-2100 series

BOOSTER REGULATOR

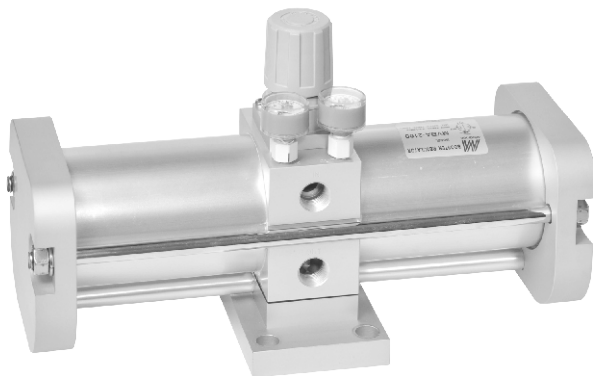

Features

- Increase factory air pressure by up to twice as much.
- Air-only operation requires no power supply, reduces heat generation, and allows easy installation.

Specification

Model	MVBA-2100
Port size	Rc3/8
Medium	Air
Pressure increase rate	Twice
Operating pressure range	0.2~1 MPa
Supply pressure range	0.1~1 MPa
Proof pressure	1.5MPa
Max. flow rate (※)	1000 ℓ/min
Ambient temperature	+2~+50℃
Installation	Horizontal
Lubrication	Grease (Non-lube)
Attachment	Pressure gauge (PG-25)
Option	Silencer (MSLT-03)
Weight	3900 g

Order example

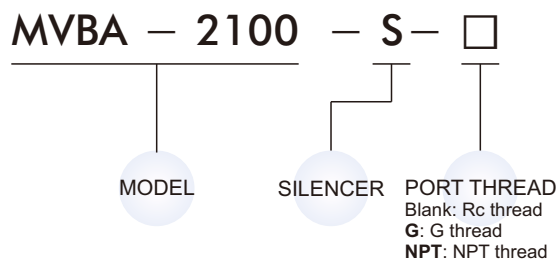

※ Max. flow rate at In=Out=0.5 MPa.

Caution

- If the outlet capacity is undersized, pulsation may occur.
- Make sure to install a mist separator at the inlet side of the booster regulator.
- The booster regulator has a sliding part inside, and it generates dust. Also, install a cleaning device such as an air filter or a mist separator on the outlet side as necessary.
- Provide a dedicated pipe to release the exhaust air from each booster regulator. If exhaust air is converged into a pipe, the back pressure that is created could cause improper operation.
- Depending on the necessity, install a silencer on the exhaust port of the booster regulator to reduce the exhaustion sound.
- Allow the sufficient space for maintenance and inspection.

Dimensions

